



Owners Manual DefendAir® HEPA 500 Air Scrubber

Model F284

LEGEND BRANDS, INC.

15180 Josh Wilson Road, Burlington, WA 98233

Phone: 800-932-3030 Fax: 360-757-7950 LegendBrandsRestoration.com

The DefendAir HEPA 500 is a portable filtration system that draws air in from the surrounding environment and passes it through an advanced filtration system. The unit removes airborne particles such as dust, mold spores, pollen, pet dander and other debris, and can also be configured to remove odors.

Patents: <http://www.LBpatents.com>

READ AND SAVE THESE INSTRUCTIONS

WARNING

WARNING! Do not alter or modify your HEPA 500 in any way. Use only replacement parts authorized by Legend Brands, Inc. Modifications or use of unapproved parts could create a hazard and will void your warranty. Contact your authorized Dri-Eaz distributor for assistance.



WARNING! Electric shock hazard, rotating fan, hot surface hazards. Unplug unit before opening cover for cleaning or servicing. Unit must be grounded.

- Inspect the power cord before use. If cord is damaged, do not use. Always grasp the plug (not the cord) to unplug.
- Plug cord firmly into base of unit first, then into electrically grounded outlet. Do not use adapter. Never cut off third prong. Do not use an extension cord.
- To keep power cords from pulling the unit, be sure to insert the plugs firmly and engage the cords in the cord clips attached to back of unit.
- Do not attempt to repair the unit. For Authorized Service Centers, check the "How to Buy" section at LegendBrandsRestoration.com or call Dri-Eaz at 800-932-3030.

If the power cord is damaged, it must be replaced by the manufacturer, its service agent or similarly qualified persons in order to avoid a hazard.

WARNING

- Do not operate any fan with a damaged cord or plug. Discard fan or return to an authorized service facility for examination and/or repair.
- Do not run cord under carpeting. Do not cover cord with throw rugs, runners, or similar coverings. Do not route cord under furniture or appliances. Arrange cord away from traffic area and where it will not be tripped over.

INTRODUCTION

The HEPA 500 uses a combination of airflow and filtration to create cleaner air. The unit draws air through two types of filters – a pre-filter and a HEPA filter. The first stage of filtration captures larger particles. When fitted with the optional Activated Carbon Filter, the first stage can also adsorb a wide variety of odor compounds. The second stage of filtration captures much smaller particles down to 0.3 microns.

BEFORE YOU BEGIN

Warranty registration

Visit Warranty.LegendBrandsRestoration.com to register your

Parts Identification

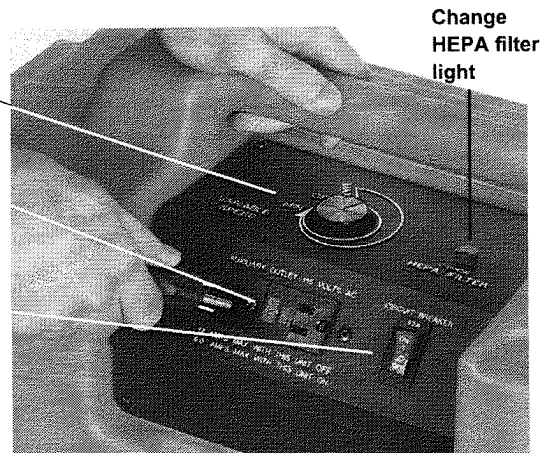
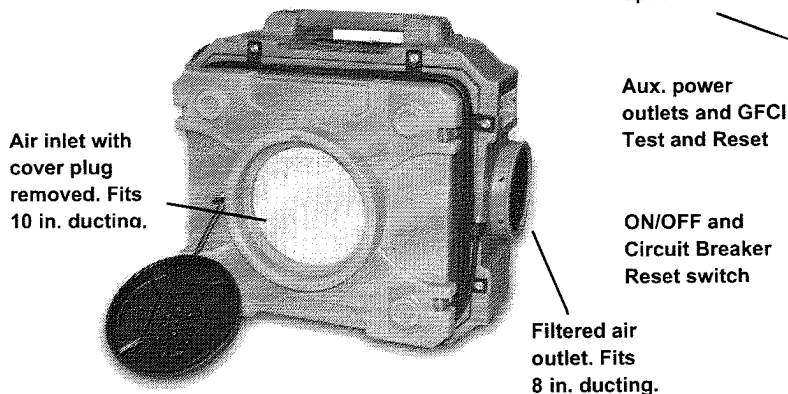
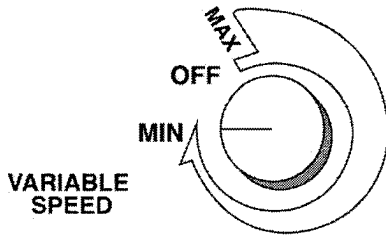

Fig. 1: Speed Control



purchase. Registration allows us to better assist you with using, maintaining or servicing your equipment, as well as to contact you in case we have important safety information concerning this product. If you determine service is required, have your equipment model, serial number and original proof of purchase available and call your distributor for assistance with obtaining a return material authorization (RMA).

ELECTRICAL SAFETY

The HEPA 500 has two features designed to protect the machine and the operator from electrical hazards.

1. Circuit Breaker. The On/Off switch incorporates a circuit breaker to protect the machine from excessive electrical current by automatically turning the unit off when more than 12 amps run through the unit's circuitry. If the circuit breaker trips, first reduce the number of units connected to the main unit via "daisy chain," then press the On/Off switch to reset.

2. GFCI. The HEPA 500 is also equipped with Ground Fault Circuit Interrupter (GFCI). The GFCI helps to protect the user against electric shock. If the system detects a ground fault, the GFCI will instantly interrupt the electric current. The GFCI will also trip when a short circuit or an overload occurs.

NOTICE: If the GFCI trips, unplug the unit, and look for potential electrical hazards – standing water, worn or frayed cords – anything that would cause a surge of electrical current. Once you've addressed these problems, press the red "Reset" button and check for proper operation. To isolate the problem, it may be useful to relocate the unit and plug it into a different outlet. If the GFCI continues to trip after you've addressed any obvious problems, please contact your Dri-Eaz distributor for assistance.

HEPA 500 APPLICATIONS

Water Damage

Use of the HEPA 500 within the affected area will reduce particle levels during the restoration process. In a standard Category 1 water damage situation, place the HEPA 500 in the middle of the affected area. Category 2 and 3 water damage situations may require negative pressure containment and other precautions. Only professionals with the appropriate training should use containment techniques.

Mold Remediation

Most mold remediation projects require containment. Containment prevents the spread of mold spores and other bioaerosols. Always use the optional DOP Filter (F415)

Fig. 2: GFCI Ground Fault Interrupter

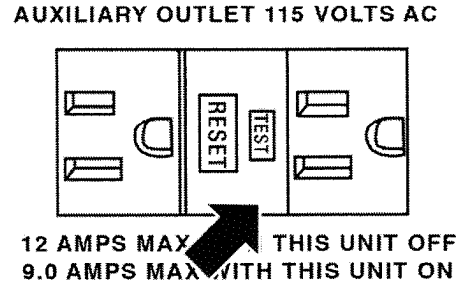

when using the HEPA 500 to ensure first-pass filtration in a containment setup. Only a professional with the appropriate training should attempt mold remediation.

Odor control

When used with the optional Activated Carbon Filter (F397), the HEPA 500 can effectively remove many odors from an indoor air environment, including volatile organic compounds (VOCs), food odors, fumes from paint and paint thinners, sewer odors, and many others.

Other uses: The HEPA 500 can be used in a wide variety of situations, including abatement, dust control, fire damage remediation, jobsite ventilation, positive or negative air setups for contamination cleanup and cleanroom environments, and general air scrubbing. Use in institutions, schools, hospitals, long term care facilities, construction and remodel job sites – anywhere that that professional grade air quality control is needed to control indoor air quality and protect the health and safety of workers and occupants.

IMPORTANT: Many of these applications can present significant health risks and require professional training. For more information about using the HEPA 500 for restoration and remediation projects, consult the IICRC at 360-693-5675 or visit www.IICRC.org. You can also contact Restoration Sciences Academy at 800-932-3030 for technical advice and information about Academy courses.

NOTICE! Because federal, provincial and local laws and regulations have varying requirements for the application, testing and general use of equipment on asbestos abatement projects, Dri-Eaz cannot warrant the use of any product we manufacture for asbestos abatement. Contractors performing abatement work should evaluate tools, equipment and procedures in light of their local **regulatory requirements, and**

Fig. 3: HEPA Filter Change Light



Fig. 4: On/Off Switch and Circuit Breaker

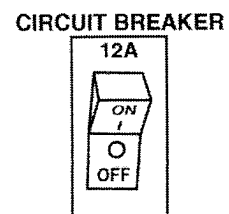

comply with those requirements.



WARNING: BREATHING HAZARD

When using the HEPA 500 in a containment area, turn off all sources of power to open combustion appliances such as fireplaces, boilers, furnaces, water heaters and HVAC systems to avoid the risk of backdrafting deadly carbon monoxide fumes.

CONTROLS AND OPERATING INSTRUCTIONS

Variable Speed Control knob

Increase the fan speed by turning the knob (Fig. 1) clockwise. Fan speed can be adjusted between 250 and 500 CFM.

Change Light

The change light (Fig. 3) illuminates when you need to change the HEPA filter.

Electrical Outlets

You can “daisy chain” or interconnect up to 3 HEPA 500s to customize your air filtration needs. The unit can conduct a maximum of 12 amps when it is turned off, and 9 amps when it is turned on. That means you can plug other equipment into the unit, but the amperage is limited.

Setup

1. Unwrap the cord wrap completely
2. Place the HEPA 500 upright (vertical with handle at the top)
3. Plug in to a standard 115 volt outlet. Each HEPA 500 needs 3 amps to operate.
4. To switch the unit on, locate the control panel and turn the variable speed switch clockwise (see Fig. 1 “Speed Control” above). Then select either a maximum (500 CFM) or down to a minimum (250 CFM) airflow rate. To maintain the optimal air change rate, consult the IICRC S520 standards, 10.3.1.

Special Features

Daisy-chain capability

An onboard auxiliary power outlet allows for the connection of up to three HEPA 500 units to create a maximum of 500, 1000, or 1500 CFM.

Ducting options

The HEPA 500 has a standard ductable 12 in. inlet and a ductable 8 in. outlet, suitable for use with rigid and layflat ducting. See “Ducting Options,” p. 5, for descriptions of the ducting types available from Dri-Eaz.

Negative Pressure Setup

The HEPA 500 can be configured to set up a negative pressure containment area. Install the HEPA 500 outside the containment area to draw air out. Only professionals with the appropriate training should set up negative pressure containment areas.

Options for Storage and Operation

The HEPA 500 can be stacked up to two high for storage or operation. The handle of one unit fits snugly into the bottom of a second unit. The unit can also be operated on its back, with the outlet facing upward.

For storage, HEPA 500s may be stacked horizontally or vertically. Secure the unit properly when transporting.

About the filters

The HEPA 500 uses two types of disposable filters: prefilters and a HEPA filter. The prefilter section can be fitted with one or two filters. These prefilters are designed to capture larger airborne particles and to control odors, depending on the filter selected. The HEPA section (Position 3), is fitted with a filter designed to capture 99.97% of smaller particles down to 0.3 microns. See Fig. 7, Filter Positions, and “HEPA 500 Filter Configurations,” p. 5, for details.

Filters should be replaced whenever they show visible accumulation of dust. For environments with a high volume of aerosolized particles, we recommend the use of two prefilters to extend the life of the HEPA filter.

Always replace the HEPA filter promptly when the Filter Change Light illuminates. Do not attempt to vacuum and reuse the HEPA filter.

NOTICE: When using the HEPA 500 on remediation projects, the filters should be changed and properly disposed of after every job.

Replacement filters are available from your Dri-Eaz distributor.

Fig. 5: Replacing the prefilters

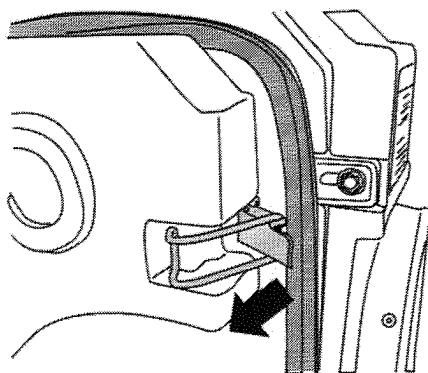

Release the four spring clips (one shown here) and lift off cover to access the prefilter(s).

Fig. 6: Replacing the HEPA filter

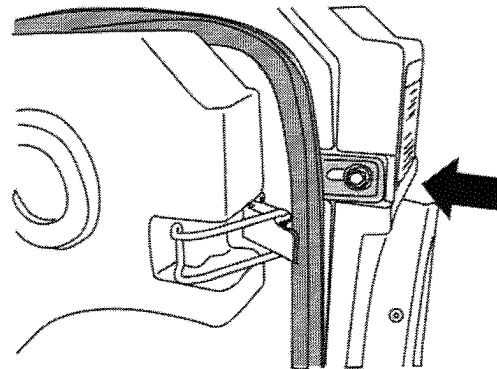

Remove the eight bolts and tabs (one shown here) and lift off cover to access the HEPA filter.

MAINTENANCE

WARNING



WARNING! ELECTRIC SHOCK HAZARD. Disconnect from electrical supply prior to servicing or cleaning.



WARNING! BREATHING HAZARD. Always wear an appropriate NIOSH-approved respirator and personal protective equipment when removing or replacing filters, or when cleaning the HEPA 500.

Before each use

1. Inspect the electrical cord for damage, and do not use the unit if you find any fraying, cuts, etc. Contact your local Dri-Eaz distributor for service.

2. Test GFCI protection. Plug the unit in and turn it on. Now depress the blue GFCI Test button. If it is operating properly the machine will turn off and the red Reset button will pop up. Press the Reset button to resume normal operation.

As Needed

Clean housing and impeller. Lay the unit on its back and loosen the four filter cover clamps (Fig. 5). Lift off the filter cover and remove any prefilters present. Use a 3/8 in. wrench to loosen the 8 retaining tab nuts holding the inlet panel in place. Slide the retaining tabs outward away from the center of the inlet panel, and lift off the inlet panel.

Always replace the HEPA filter promptly when the Filter Change Light illuminates. Do not attempt to vacuum and reuse the HEPA filter.

Filters

The **prefilters** should be inspected regularly and changed whenever dust has visibly accumulated on the filter surface.

The HEPA filter should be changed whenever the change filter light (Fig. 3) comes on.

See "HEPA 500 Filter Configurations," p. 5, for the available filter combinations.

Water damage restoration applications

Before each use

Look for accumulated dust and dirt that could restrict airflow through the filter into the unit. If any is visible, change out the pre-filter.

Remediation applications

- Wear NIOSH-approved protective gear when changing filters.
- Change filters after every remediation job.
- Change HEPA filter when the filter indicator light (Fig. 3) comes on.
- Dispose of used filters according to local regulations.
- Replace both the prefilters and HEPA filter to prevent cross-contamination.
- Clean the unit thoroughly (vacuum and damp wipe per IICRC S520, 10.11) after each job before removing it from the containment area to avoid cross-contamination. Pay particular attention to the area around the air intake. Let the unit dry before installing clean filters.

Filter access instructions

To inspect and change the prefilters, lay the unit flat on its back. Lift and release the four latches on the outlet panel and lift off the panel. Inspect and/or replace the prefilters as necessary.

After ensuring that the prefilter(s) are properly seated, replace the outlet panel, and re-engage the latches. The HEPA 500 is now ready to return to service.

To change the HEPA filter, lay the unit flat on its back, then use a 3/8 in. wrench to loosen the 8 retaining tab nuts holding the inlet panel in place. Slide the retaining tabs outward, away from the center of the inlet panel, and lift off the inlet panel.

Lift out the used HEPA filter and replace it with a new one. Do not clean and reuse the HEPA filter.

After making sure that the filter is properly seated, replace the inlet panel, slide the tabs back into place, and tighten the nuts. Do not overtighten. The HEPA 500 is now ready to return to service.

About DOP first-pass filtration efficiency

DOP (Dispersed Oil Particulate) first-pass efficiency refers to a standard procedure for testing the effectiveness of HEPA filtration. The DOP test introduces a dense cloud of extremely fine particulates into the filter under controlled conditions. DOP verification is required in certain settings.

The addition of the DOP filter (F415) makes the HEPA 500 a high efficiency three-stage air filtration unit suitable for any job that requires first-pass HEPA filtration.

Install the DOP filter between the standard pre-filter and the HEPA primary filter. For odor control, the Activated Carbon Filter may be used together with the DOP filter. Simply replace the pre-filter with the carbon filter.

ADDITIONAL RESOURCES

- *Dri-Eaz Guide to Air Scrubbing*. Visit LegendBrandsRestoration.com to download or order a copy.
- Institute of Inspection, Cleaning and Restoration Certification (IICRC), 360-693-5675.
- *S520: The Standard and Reference Guide for Professional Mold Remediation*, call the IICRC at 360-693-5675.
- Dri-Eaz website: LegendBrandsRestoration.com

Fig. 7: Filter Positions

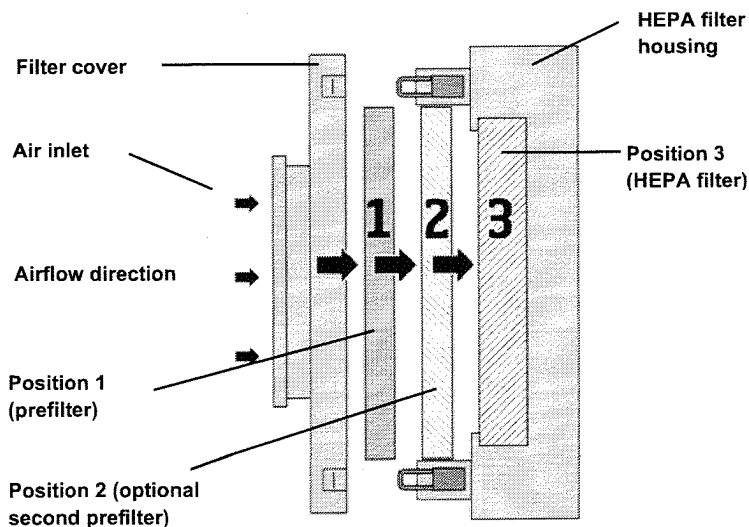

- Restoration Sciences Academy 800-932-3030
www.RestorationSciencesAcademy.com
- NIOSH help line: 800-35-NIOSH. Provides respirator and

respirator filter information.

HEPA 500 FILTER CONFIGURATIONS

Filtering Application	PREFILTERS (Positions 1 & 2)		HEPA (Position 3)
	Clean water loss air scrubbing. For a relatively clean environment.	n/a	30% Prefilter (F271)
Standard air scrubbing. For environments with higher particle loads, such as construction or remodeling sites.	10% Prefilter (F270)	30% Prefilter (F271)	HEPA filter (F321)
First-pass efficiency air filtration. For use with a negative air setup during remediation of high risk contaminants and/or when DOP testing is required. See "About DOP First-Pass Filtration Efficiency," p. 4.	30% Prefilter (F271)	DOP Prefilter (F415)	HEPA filter (F321)
Odor control and air filtration. For removing volatile organic compounds (VOCs), food odors, fumes from paint and paint thinners, sewer odors, and many other noxious odors.	Activated Carbon Filter (F397)	30% Prefilter (F271)	HEPA filter (F321)

FILTER DESCRIPTIONS

10% Prefilter (F270). Synthetic fiber filter media rated at 10% efficiency. Captures the largest particles to help extend the life of the higher efficiency filters inside.

30% Prefilter (F271). Synthetic fiber filter media rated at 30% efficiency. Captures larger particles to help extend the life of the HEPA filter.

Activated Carbon Filter (F397). The use of activated carbon in this filter allows the removal of a wide variety of compounds, including volatile organic compounds (VOCs), food odors, fumes from paint and paint thinners, sewer odors, and many other noxious odors. Combining activated carbon filtration with HEPA filtration is especially effective in removing airborne soot particles and the odors they create.

DOP Prefilter (F415). Use the DOP filter to ensure laboratory-rated performance for sensitive jobs requiring first-pass HEPA filtration.

HEPA filter (F321). The HEPA filter has an efficiency rating of 99.97% against 0.3 micron oily aerosol particles.

DUCTING OPTIONS

12 in. rigid ducting (Sto & Go Ducting, F405) for inlet. 25 feet of collapsible 12-inch ducting with a built-in protective case. Connect one or more sections. Packs into convenient carry case.

8 in. layflat ducting (F268) for outlet. Strong 4-mil poly ducting. 13 in. wide when flat; expands to 8.3 in. diameter when inflated. 500 feet per roll. Cut to length.

TROUBLESHOOTING

PROBLEM	CAUSE	SOLUTION
Unit does not operate	<ol style="list-style-type: none"> 1. No power to machine 2. Switch not turned on 3. No power at supply outlet 4. GFCI tripped 	<ol style="list-style-type: none"> 1. Plug in the unit; check power at outlet 2. Turn on the switch 3. Reset supply circuit breaker/GFCI 4. Reset unit circuit breaker/GFCI
Change light illuminated	<ol style="list-style-type: none"> 1. Primary (HEPA) filter is full 2. Air intake restricted by ducting bends, kinks, or excessive length 	<ol style="list-style-type: none"> 1. Replace the HEPA filter 2. Eliminate bends/kinks in ducting; reduce ducting length.
<p><i>For any problems not described here, please contact your local distributor for assistance.</i></p>		

SPECIFICATIONS

Model	HEPA 500 (F284)
Weight	44 lbs. 19.9 kg
Dimensions (D × W × H)	24.6 × 26.2 × 18.2 in. 62.5 × 66.5 × 46.2 cm
Duct sizes	Intake: 12 in. Outlet: 8 in.
Power	3A, 115V, 60 Hz
Air movement	250–500 CFM
Static pressure	2.9 in. (H ₂ O)
Filter system	Up to two prefilters and one HEPA filter.
Controls	On/Off switch, variable speed control knob
Power cord length	25 ft. 7.63 m
Construction	Rotomolded polyethylene housing
Safety	UL/cUL listed
<p><i>Specifications are subject to change without notice. Some values may be approximate.</i></p>	



WARNING: Because federal, provincial and local laws and regulations have varying requirements for the application, testing and general use of equipment on asbestos abatement projects, Legend Brands, Inc., cannot warrant the use of any product we manufacture for asbestos abatement. Contractors performing abatement work should evaluate tools, equipment and procedures in light of their local regulatory requirements, and comply with those requirements.



WARNING: This product and other substances that may become airborne from its use contain chemicals, including lead and phthalates, known to the State of California to cause cancer, birth defects, or other reproductive harm. For more information, go to P65Warnings.ca.gov